



Hi3516D V300 Professional Smart IP Camera SoC

## **Brief Data Sheet**

<b>Issue</b>	<b>02</b>
<b>Date</b>	<b>2018-08-22</b>

**Copyright © HiSilicon Technologies Co., Ltd. 2018. All rights reserved.**

No part of this document may be reproduced or transmitted in any form or by any means without prior written consent of HiSilicon Technologies Co., Ltd.

### **Trademarks and Permissions**



**HISILICON**, and other HiSilicon icons are trademarks of HiSilicon Technologies Co., Ltd.

All other trademarks and trade names mentioned in this document are the property of their respective holders.

### **Notice**

The purchased products, services and features are stipulated by the contract made between HiSilicon and the customer. All or part of the products, services and features described in this document may not be within the purchase scope or the usage scope. Unless otherwise specified in the contract, all statements, information, and recommendations in this document are provided "AS IS" without warranties, guarantees or representations of any kind, either express or implied.

The information in this document is subject to change without notice. Every effort has been made in the preparation of this document to ensure accuracy of the contents, but all statements, information, and recommendations in this document do not constitute a warranty of any kind, express or implied.

## **HiSilicon Technologies Co., Ltd.**

Address: New R&D Center, Wuhe Road,  
Bantian, Longgang District,  
Shenzhen 518129 P. R. China

Website: <http://www.hisilicon.com>

Email: [support@hisilicon.com](mailto:support@hisilicon.com)



# Hi3516D V300 Professional Smart IP Camera SoC

## Key Specifications

### Processor Core

- Dual-core ARM Cortex-A7@ 900 MHz, 32 KB I-cache, 32 KB D-cache, 256 KB L2 cache
- Neon acceleration and integrated FPU

### VEDU

- H.264 BP/MP/HP
- H.265 MP
- I-/P-frames and SmartP reference.
- MJPEG/JPEG baseline

### VEDU Performance

- Up to 2688-pixel wide and 2688 x 1944 resolution for H.264/H.265 encoding and decoding. Only the decoding of self-encoded streams is supported..
- Real-time multi-stream H.264/H.265 encoding and decoding:
  - 2688 x 1536@30 fps encoding +720 x 480@30 fps encoding + 360 x 240@30 fps encoding
  - 2688 x 1944@20 fps encoding +720 x 480@20 fps encoding + 360 x 240@20 fps encoding
  - 1920 x 1080@30 fps encoding + 720 x 480@30 fps encoding + 1920 x 1080@30 fps decoding
- JPGE encoding and decoding performance: 16M (4608 x 3456) @10 fps
- Five bit rate control modes (CBR, VBR, FixQp, AVBR, and QpMap)
- Up to 50 Mbit/s output bit rate
- Up to 8-ROI encoding

### Smart Video Analysis

- Neural network acceleration engine with processing performance up to 1.0 TOPS
- Smart computing acceleration engine (including tracking and face image correction)

### Video and Graphics Processing

- 3DNR, image enhancement, and DCI
- Anti-flicker processing for video and graphics output
- 1/15–16x video and graphics scaling
- Video graphics overlay
- 90°, 180°, and 270° image rotation
- Image mirroring and flipping
- Up to 8-region OSD overlay before encoding

### ISP

- 3A functions (AE, AF, and AWB), supporting third-party 3A algorithms
- FPN removal and DPC
- LSC, LDC, and purple fringing correction
- Direction-adaptive demosaic
- Gamma correction, DCI, and color management and enhancement
- Region-adaptive dehaze
- Multi-level NR (including BayerNR and 3DNR), detail enhancement, and sharpening enhancement

- Local tone mapping
- Sensor built-in WDR and 2F WDR (line-based/frame-based/DCG)
- Video-/Gyro-based 6-DoF IS
- ISP tuning tools for the PC

### Audio Encoding and Decoding

- Multi-protocol audio encoding and decoding (G.711, G.726, and ADPCM) by using software
- Audio 3A functions (AEC, ANR, and ALC)

### Security

- Secure boot
- Hardware-based memory isolation
- Hardware-based encryption and decryption algorithms (including AES, DES, 3DES, and RSA)
- Hardware-based HASH algorithms (SHA1/SHA256/HMAC\_SHA/HMAC\_SHA256)
- Hardware random number generator
- 8-kbit OTP storage space

### Video Interface

- VI
  - 2-channel VI
    - Up to 2688-pixel wide and 2688 x 1944 resolution for input of the first channel
    - Up to 2048-pixel wide and 2048 x 1536 resolution for input of the second channel
  - 8-/10-/12-/14-bit RGB Bayer DC timing VI
  - BT.601, BT.656, and BT.1120 VI interfaces
  - MIPI, LVDS/sub-LVDS, and HiSPi
  - Compatibility with mainstream HD CMOS sensors provided by vendors such as Sony, ON, OmniVision, and Panasonic
  - Compatibility with the electrical specifications of parallel and differential interfaces of various sensors
  - Programmable sensor clock output
- VO
  - One BT.656/BT.1120 VO interface
  - 6-/8-bit RGB serial LCD VO and 16-/18-/24-bit RGB parallel LCD VO
  - 4-lane MIPI-DSI VO
  - HDMI 1.4 output with a maximum resolution of 1080p60

### Audio Interface

- Audio codec, supporting 16-bit input and output
- Mono-channel differential MIC input for background NR
- Single-end dual-channel input
- I<sup>2</sup>S interface for connecting to external audio codec

### Peripheral Interface

- POR
- High-precision RTC
- 2-channel LSADC
- I<sup>2</sup>C interfaces, SPIs, and UART interfaces
- Three PWM interfaces
- Two SDIO 3.0 interfaces, supporting the 3.3 V/1.8 V level



# Hi3516D V300 Professional Smart IP Camera SoC

- SD 3.0 card supported over one SDIO 3.0 interface
- One USB 2.0 host/device interface
- RMI mode, TSO network acceleration, 10/100 Mbit/s full-duplex or half-duplex mode, and PHY clock output

## External Memory Interface

- SDRAM interface
  - 32-bit DDR3(L)/DDR4 SDRAM, supporting a maximum capacity of 16 Gbits
  - Up to 1800 Mbit/s rate
- SPI NOR flash interface
  - 1-/2-/4-line mode
  - Maximum capacity of 256 MB
- SPI NAND flash interface
  - Up to 24 bit/1 KB ECC performance
  - Maximum capacity of 1 GB
- eMMC 4.5 interface
  - 4-bit data width

## Startup

Booting from the SPI NOR flash, SPI NAND flash, or eMMC

## SDK

- Linux-4.9-based SDK
- High-performance H.264 PC decoding library
- High-performance H.265 PC, Android, and iOS decoding libraries

## Physical Specifications

- Power consumption
  - Typical power consumption at 4M (2688 x 1536)P30 fps: TBD
- Operating voltage
  - 0.9 V core voltage
  - 3.3 V I/O voltage ( $\pm 10\%$ )
  - 1.5 (1.35) V/1.2 V DDR3(L)/4 SDRAM interface voltage
- Package

## Functional Block Diagram

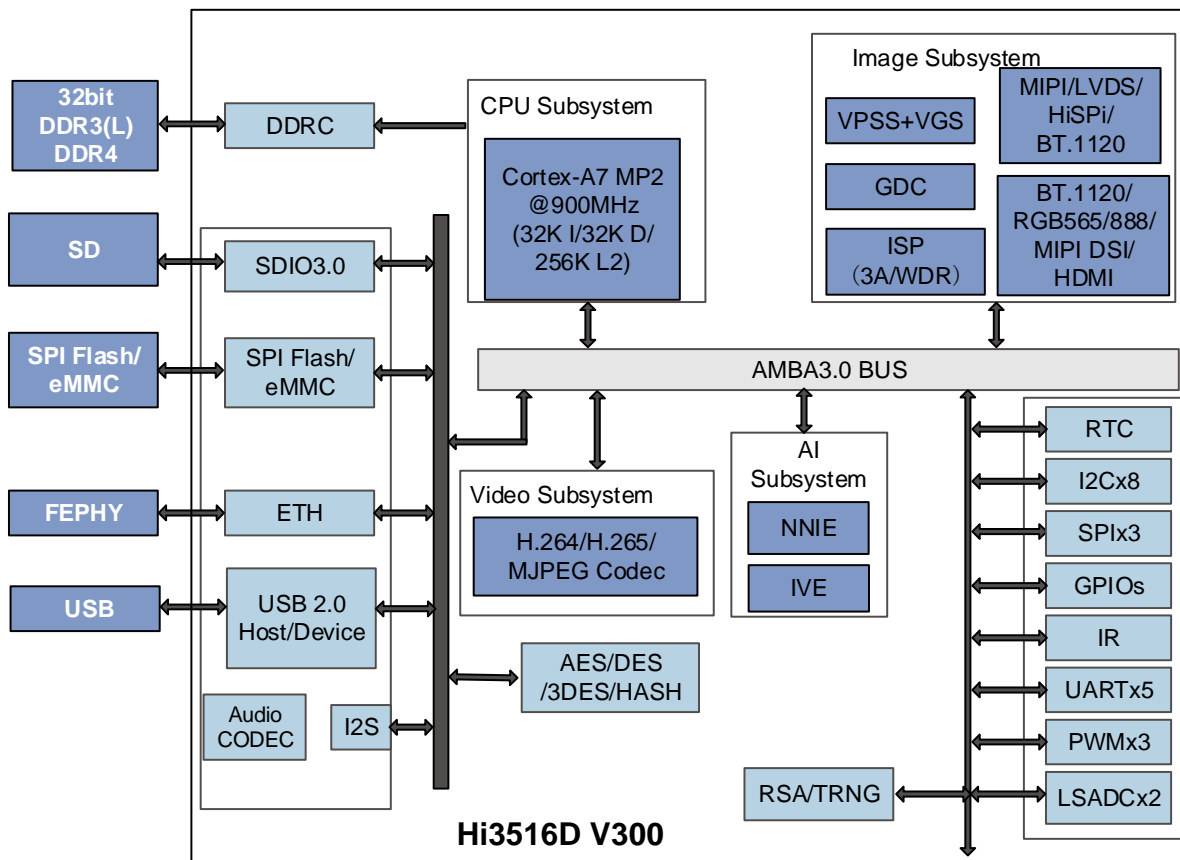

Hi3516D V300 is a new-generation SoC designed for the industry-dedicated smart HD IP camera. It introduces a new-generation ISP, the latest H.265 video compression encoder, and a high-performance NNIE engine, enabling Hi3516D V300 to lead the industry in terms of low bit rate, high image quality, intelligent processing and analysis, and low power consumption. Integrated with the POR, RTC, audio codec, and standby wakeup circuit, Hi3516D V300 can greatly reduce the EBOM costs for customers. Hi3516D V300 also provides similar interface designs to the HiSilicon DVR and NVR SoCs, facilitating rapid mass production.



## Hi3516D V300 Professional Smart IP Camera SoC

Body size of 14 mm x 14 mm (0.55 in. x 0.55 in.), 0.65 mm (0.03 in.) ball pitch, TFBGA RoHS package with 367 pins



# Hi3516D V300 Professional Smart IP Camera SoC

## Hi3516D V300 HD IP Camera Solution

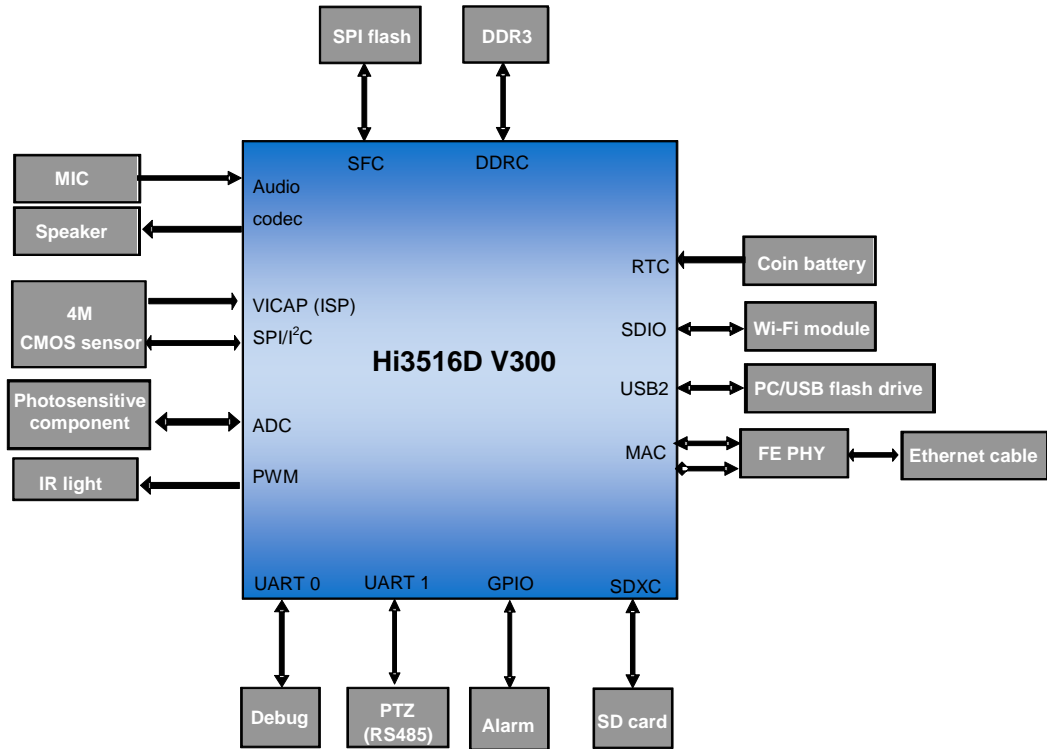



## Acronyms and Abbreviations

3DNR	three-dimensional noise reduction
6DoF	six degrees of freedom
AE	automatic exposure
AEC	acoustic echo cancellation
AF	automatic focus
ALC	automatic level control
ANR	audio noise reduction
AVBR	adaptive variable bit rate
AWB	automatic white balance
CBR	constant bit rate
codec	coder/decoder
DC	digital camera
DCG	Dual Conversion Gain
DCI	dynamic contrast improvement
DDRC	double data rate controller
DPC	defect pixel correction
DVR	digital video recorder
EBOM	engineering bill of materials
ECC	error-correcting code
FPN	fixed pattern noise
I <sup>2</sup> C	inter-integrated circuit
IR	infrared
LCD	liquid crystal display
LDC	lens distortion correction
LSADC	low-speed analog-to-digital converter
LSC	lens shading correction
NNIE	neural network inference engine
NR	noise reduction
NVR	network video recorder
OSD	on-screen display
OTP	one-time programming
POR	power-on reset
PWM	pulse-width modulation
RMII	reduced media-independent interface
ROI	region of interest
RTC	real-time clock
SDIO	secure digital input/output
SoC	system-on-chip
SPI	serial peripheral interface
TFBGA	thin & fine ball grid array
TOPS	tera operations per second
UART	universal asynchronous receiver transmitter
VBR	variable bit rate
VENC	video encoding
VI	video input
VO	video output
WDR	wide dynamic range